



XIMUJIATM
flexible system

storage | shelving | wardrobes | office

welcome

The Ximula™ Flexible System provides unlimited design possibilities, technical innovation and exquisite craftsmanship with its award winning collection.

The patented aluminium joinery concept allows you to mix a range of cabinets, shelves, drawers, rails and doors to create your perfect interior.

awards

Good Design Award
(G-Mark) JAPAN

Good Design Award
(G-Mark) MALAYSIA

Furniture Excellence
GOLD, MALAYSIA

Why choose the Ximula™ Flexible System...

- Commercial quality manufacture for durability and strength
- Customised manufacture
- Simple assembly
- Aluminium profiles resist rust in coastal areas
- Infinitely adjustable shelves and cabinet heights
- Lightweight appearance perfect for small spaces
- Large range of colours and finishes available
- Add extra components as needed
- Suitable for domestic and commercial use
- Recyclable materials & excellent green credentials
- Take it with you as you move house or business
(not fixed cabinetry)
- Fully manufactured in Singapore

XIMULIATM
flexible system



Using an innovative post system for joinery, it gives the freedom to remove, add-on or adjust the height of each item such as a shelf, drawer, cabinet, hanger bars and more without the hassle of dismantling the whole system. The innovative joinery system allows for easy shipping & quick assembly.

How does the Ximula™ System work?



main posts with floor to ceiling support, wall fixed or simply free-standing.
Lengths 1000 1300 1500 2200 2400
 2500 2700 2900 3100 3500



cabinets are available in a large range of finishes & sizes, secured between posts, free-standing legs, on casters or just simply stack them on top of each other.

	D	W	H
1-door cabinet	435	500	960
2-door cabinet	435	900	480
filing cabinet	435	500	360
flip door cabinet	435	500	320

(all dimensions are in mm)

Slim natural-anodised aluminum posts with shelves in 12mm thick melamine particle board or 8mm thick glass with coloured/frosted film.



D	W
335	500
435	600
535	700
	800
	900
	1000
	1100
	1200

shelves come in a range of finishes and custom sizing.

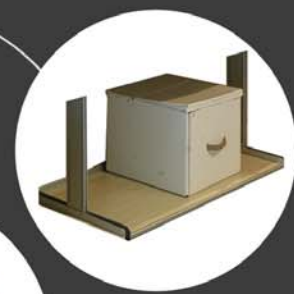

hanger bar w/ hook

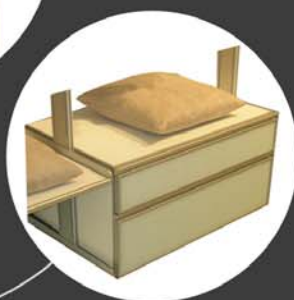

drawers are available in 1, 2, 3 or 4 tiers with a range of finishes, soft close mechanism, secured on casters or between posts.

D	W
435	500
535 to 900	

Tier Height 160/240mm

edges
 All edges trimmed with aluminium profiles.

Wardrobes & Walk-ins

The perfect wardrobe is only a dream for most people. So often we are faced with a space that is little more than a couple of shelves and a pole to hang our precious garments.

With Ximula™ your dream wardrobe is available! What's more, it is not a fixed cabinet system that's unchangeable like most others; in fact your Ximula™ wardrobe is infinitely adjustable to suit your changing needs. You can alter the heights of the drawers and hanging rails by the millimeter or add another shelf when you need it, and there is a great choice of door systems available to compliment the room.

All we need to create the design for your new wardrobe is a few simple measurements and some basic information of your needs and we can send you your tailored design today.











Storage & Entertainment Solutions

The Ximula system offers unlimited design solutions for your storage and entertainment needs and cleverly adapts to your evolving lifestyle.

Choose from a large collection of cabinets and drawers or Ximula can customise a design solution to suit your needs at no extra cost.

The Ximula system works perfectly with today's technologies and has been tested to support heavy electronic components such as large format TVs or other bulky items with ease on its patented engineered post system.

Create the perfect home cinema experience, organise the office supplies, or efficiently store your home contents and precious DVD, CD and book collection with Ximula. It's truly a system with unlimited possibilities.









Shelving Systems

Do you require the perfect bookshelves for your home or apartment, or perhaps commercial shelving for your office? Maybe you require shop fittings for a bookshop, hair salon or fashion boutique? The Ximula™ system has the most extensive range of beautiful, sleek and contemporary shelving and fittings available.

The Ximula™ flexible system is a favoured choice of Architects and Designers for homes, commercial fit-outs and in public institutions such as libraries and galleries throughout Europe, America, Asia and Australia.





Office & Workspace Solutions

Whether you require a small home office for the family or commercial workstations for a company headquarters, Ximula™ can provide options to suit all applications.

For the home office or the kids study desk, Ximula has unlimited possibilities. A large range of desks, bookshelves, filing cabinets and drawer units easily attach to the patented engineered post system which allows you to add components and alter the design as your family needs grow and change.

Commercial workstations require different specifications to suit a busy environment. Privacy screens and cable management systems along with mobile pedestals and library shelving are all catered for by the Ximula™ flexible system.









lighting

shelf

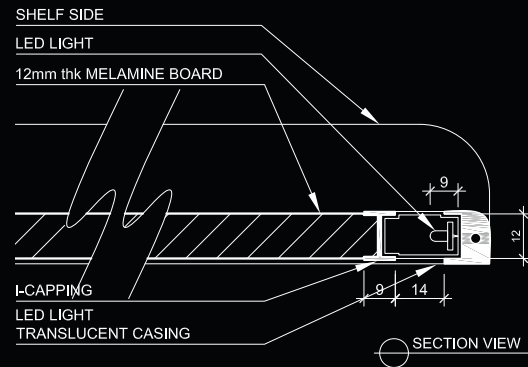

hanger bar

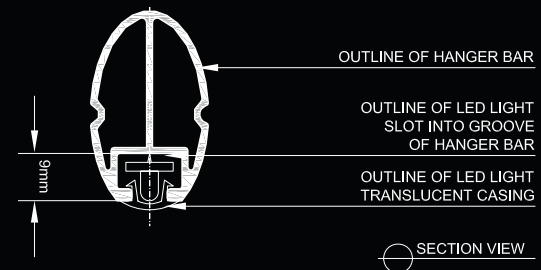

main post

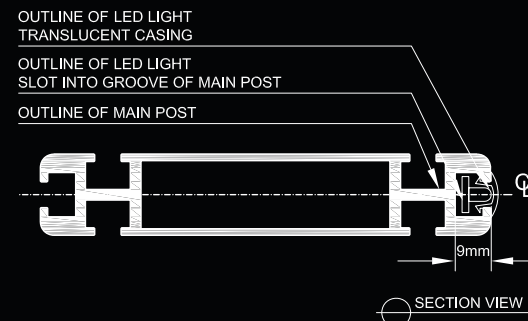



BLACK UPRIGHTS AND SHELVES



POWDER COATED FINISH

black finish

finishes

wood veins



M1 Warm white

M2 Maple

M3 White pine

M4 Iron grey

M5 White beech

M6 Walnut



M7 Red cherry

M8 Rainbow bar

M9 Red thread

M11 Red wood

coloured glass



Blue

Green

Orange

White

Red

Purple



Clear glass

Yellow

Black

Frosted

Grey



green credentials

Ximula has embraced the responsibility to respect and protect our planet by setting strict environmental standards in its manufacturing process that minimises waste and emissions that are harmful to our planet.

By using environmentally sustainable materials and understanding the benefits that recycling has from a whole of product life perspective, Ximula has successfully developed an environmentally sound product range that is both beautiful to enjoy but more importantly is friendly to our future. Ximula believes being 'Green' makes good sense because everybody benefits from it.

- Ximula's Aluminium profiles offer the 'cradle to cradle' advantage that it can be repeatedly and efficiently recycled without any loss of quality.
- Aluminium is considered the 'greenest' of metals.
- Ximula anodising does not require the use of solvents nor volatile organic compounds (VOC's) and no heavy metals are involved in the process.
- Ximula uses sustainable MEICO MFC particleboard which has gained certification to international best practice standards including CARB (US market) and has attained the prestigious BS EN ISO 14001: 1996 Environmental Management System accredited by Lloyd's Register Quality Assurance.
- MFC particleboard is manufactured from sustainable plantations of rubber trees, acacia wood and light tropical hardwoods.
- The process uses environmentally friendly resins and is free from harmful chemicals like Toluene, Xylene, Ethyl Benzene or styrene.
- The material has been independently tested in Singapore to confirm that no trace of volatile organic compounds Formaldehyde, Phenyl cyclohexene or Phthalate were detected.

common configurations

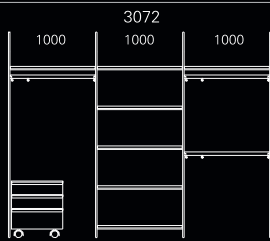

CODE:304115

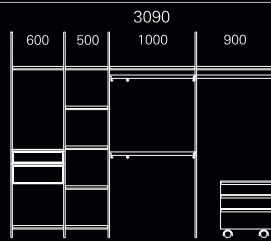

CODE:305317

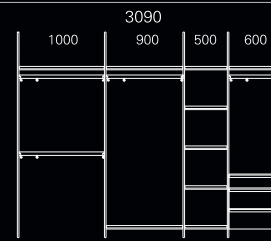

CODE:304460

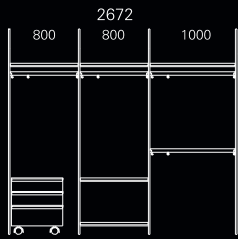

CODE:263657

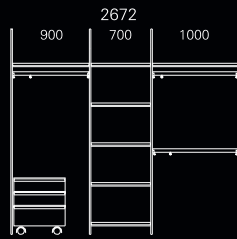

CODE:263909

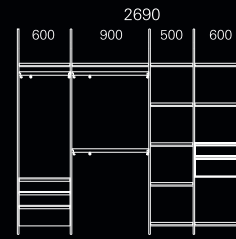

CODE:265321

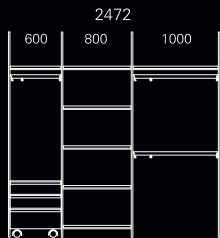

CODE:243929

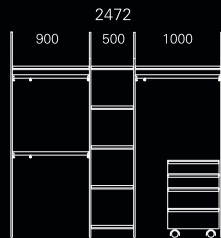

CODE:244064

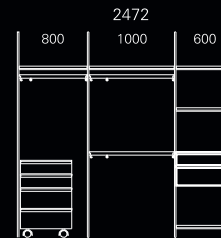

CODE:244704

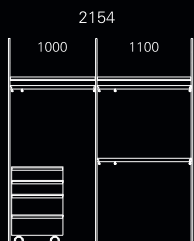

CODE:213074

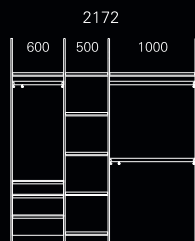

CODE:213698

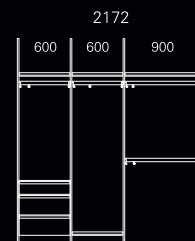

CODE:213322

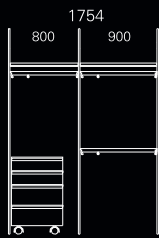

CODE:173002

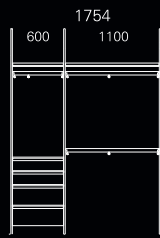

CODE:172928

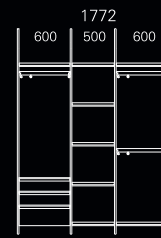

CODE:173731

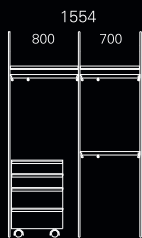

CODE:152960

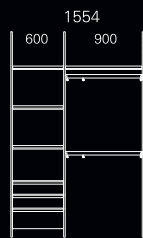

CODE:152871

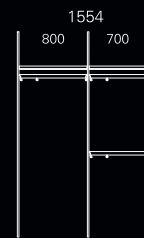

CODE:151460



CODE:132920

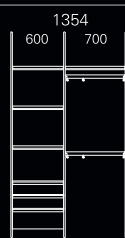

CODE:132829

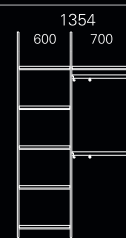

CODE:131996



29A Saddle Road, Maraval
Trinidad + Tobago

Dale Hearn

[m] +868 314 7480
[f] +868 628 9954
[e] dalehearn.icml@gmail.com

Jason Collier

[m] +868 395 2202
[e] intercaribbean@gmail.com



XIMULIATM
flexible system